

SM7135

120mA to 380mA(10mA step.) Constant Current LED Driver

Description

The SM7135 is a constant current regulator for driving LEDs with low quiescent current and low dropout voltage. The current ranges from 120mA to 380mA with 10mA step.

No external component is required to achieve a constant current LED driver. Soft start, thermal protection and low voltage protection are also provided.

Features

- Sink current: 120mA to 380mA with 10mA step.
- Power supply voltage: 2.7-6V
- Low drop out voltage: 150mV@350mA
- Low quiescent current: 250uA
- Thermal protection
- Soft start
- Low voltage protection: 2.5V
- SOT-89 and TO-252 packages

Typical Application

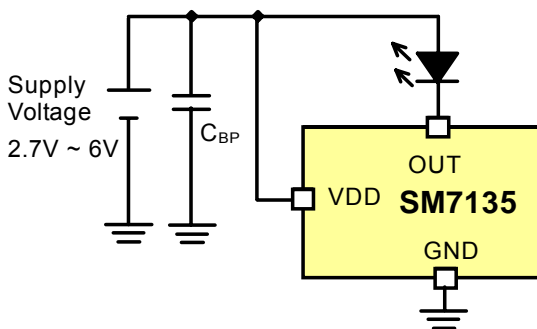

Applications

- LED Flashlight Torch
- LED Miner's Lamp
- LED Cap Lamp
- Power LED driver
- Lighting

Pin Assignment

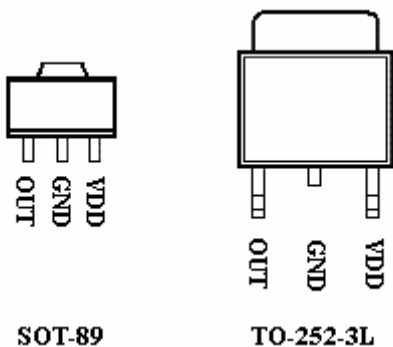

No	Symbol	Function
1	VDD	Supply Voltage
2	GND	Ground
3	OUT	Output pin, connect

Order Information

SYMBOL	DESCRIPTION
SM 7135E XX (SOT-89)	E : SOT-89 Packaging XX: Sink Current(12:120mA/13:130mA.....35:350mA.....38:380mA (120~380mA 10mA step.))
SM 7135T XX (TO-252)	T : TO-252 Packaging XX: Sink Current(12:120mA/13:130mA.....35:350mA.....38:380mA (120~380mA 10mA step.))

Functional Diagram

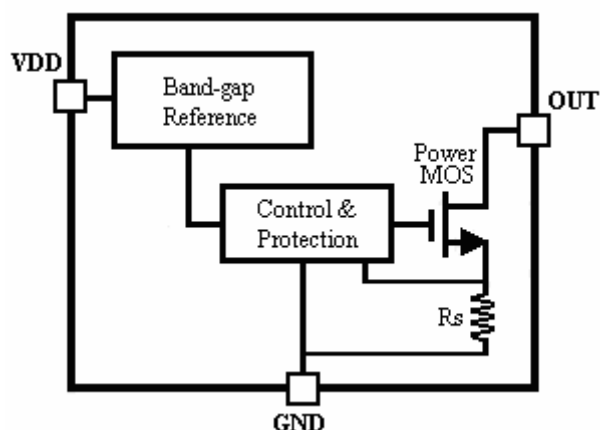

Absolute Maximum Ratings

Type	Symbol	Description	Value	Unit
Voltage	V_{max}	Maximum voltage on VDD and Vout pins	10	V
	$V_{min-max}$	Voltage range on Vout pin	-0.3~VDD+0.3	V
Current	$I_{LED_{max}}$	Maximum current on LED pin	500	mA
Power dissipation	P_{SOT-89}	Maximum Power dissipation for SOT-89	0.5	W
	P_{TO-252}	Maximum Power dissipation for TO-252	0.8	W
Thermal	$T_{min-max}$	Operation temperature range	-20~85	°C
	$T_{storage}$	Storage temperature range	-40~165	°C
ESD	V_{ESD}	ESD voltage for human body model	2000	V

Electrical Characteristics

Parameter	Symbol	Test Condition	Min	Typ	Max	Unit
Sink current range		VDD=3.6	120		380	mA
VDD range		I _{LED} =350mA	2.7		6.0	V
Sink current accuracy	$\Delta I_{LED}/I_{LED}$		-5		5	%
Load regulation		V _{LED} =0.2V to 3V VDD=3.6V			2	mA/V
Line regulation		VDD=3V to 5.5V			2	mA/V
Output dropout voltage	V_{DO}			150		mV
Supply current	I_{DD}			250		uA
Low voltage protection			2.3	2.5	2.7	V
Thermal protection				140		°C

Typical Performance Characteristics

Typical Dropout Performance

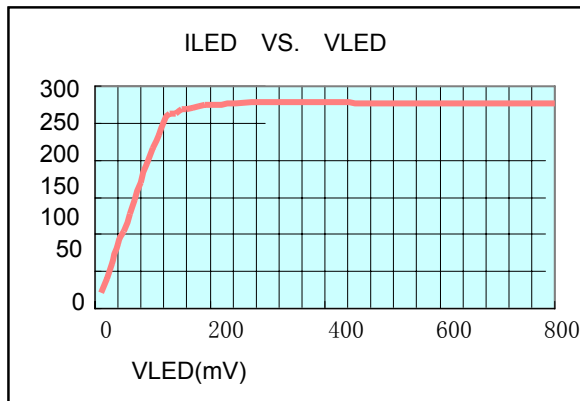

Typical Power Supply Current

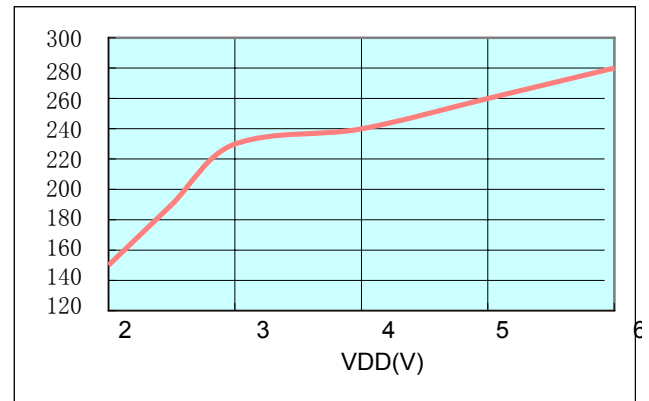

Application Information

• The maximum power dissipation on regulator

$$P_{D(MAX)} = V_{OUT(MAX)} \times I_{OUT(NOM)} + V_{IN(MAX)} \times I_Q$$

$V_{OUT(MAX)}$ = the maximum voltage on output pin

$I_{OUT(NOM)}$ = the nominal output current

I_Q = the quiescent current the regulator consumes at $I_{OUT(MAX)}$

$V_{IN(MAX)}$ = the maximum input voltage

• Thermal consideration

The SM7135 have internal power and thermal limiting circuit designed to protect the device overload conditions. However maximum junction temperature ratings should not be exceeded under continuous normal load conditions. The thermal protection circuits of SM7135 prevent the device from damage due to excessive power dissipation. When the device temperature rises to approximately 120°C, the regulator will be turned off. When power consumption is over about 700mW(SOT-89 package ,at $T_A=70^\circ\text{C}$),additional heat sink is required to Control the junction temperature below 120°C.

The junction temperature is:

$$T_J = P_D (\theta_{JT} + \theta_{CS} + \theta_{SA}) + T_A$$

P_D : Dissipated power.

θ_{JT} : Thermal resistance from the junction to the mounting tab of the package.

θ_{CS} : Thermal resistance through the interface between the IC and the surface on which is mounted.

(typically, $\theta_{CS} < 1.0^\circ\text{C/W}$)

θ_{SA} : Thermal resistance from the mounting surface to ambient (thermal resistance of the heat sink).

Packaging Information

3-Pin Surface Mount SOT-89

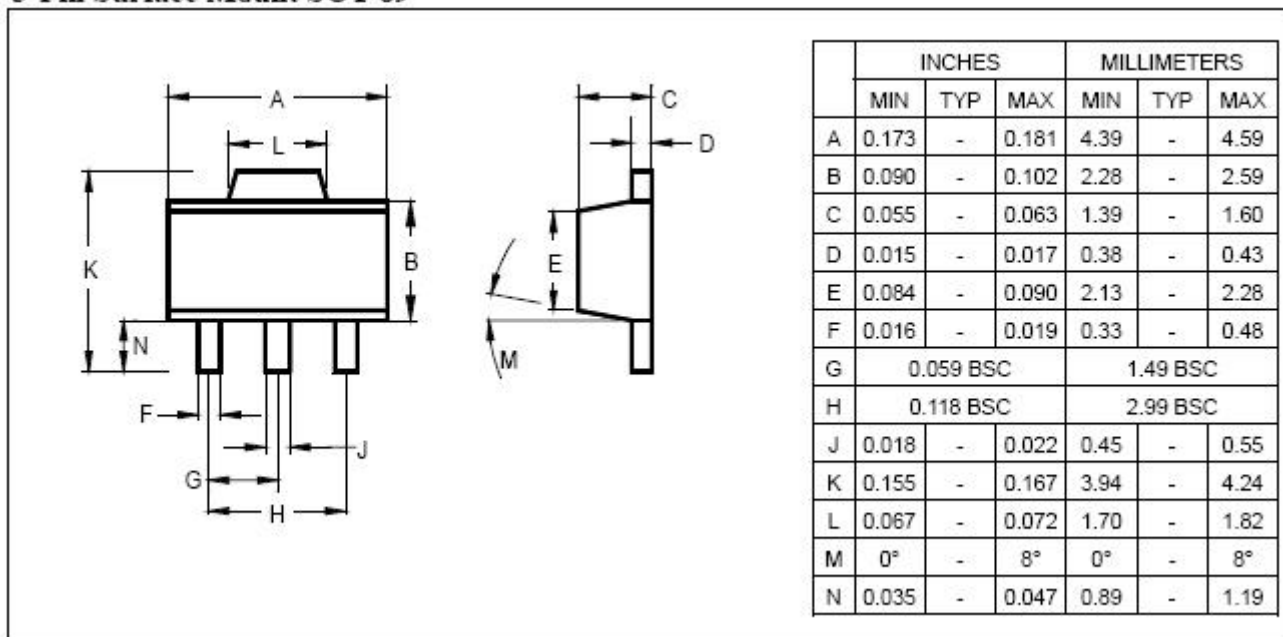

3-Pin Surface Mount TO-252

